

Tubular Inside Micrometers

SERIES 133 — Single-Rod Type

FEATURES

- With locking clamp.
- Zero point can be readjusted by rotating the micrometer head sleeve. A key wrench is supplied.
- Clear, crisp graduations on the satin-chrome finished micrometer head.
- Carbide-tipped measuring faces.
- Supplied in fitted plastic case. Over 200mm / 8" supplied in wooden case.

Technical Data

Accuracy: Refer to the list of specifications.
Graduation: 0.01mm or .001"

Optional Accessories

---- : Setting ring (See page C-29.)

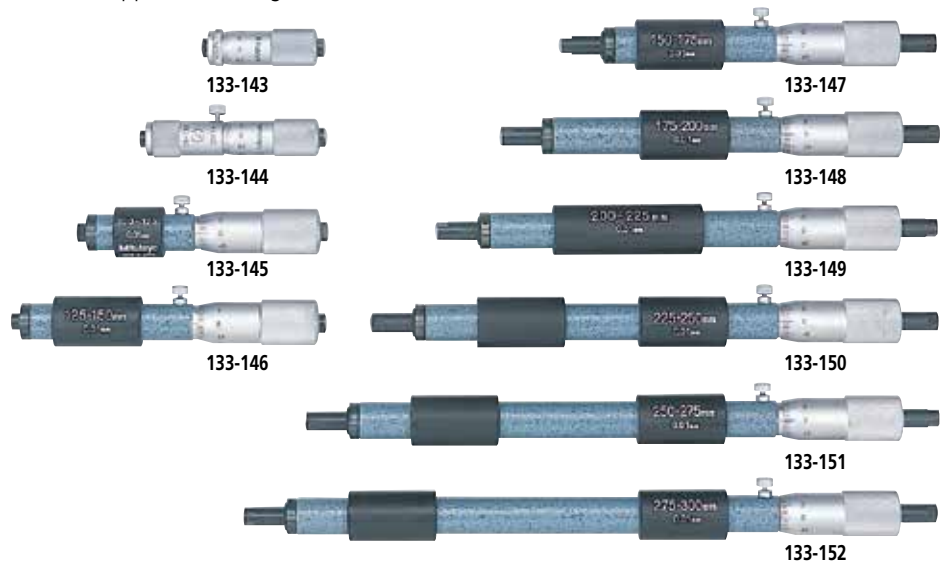

SPECIFICATIONS

Metric Individual		
Range	Order No.	Accuracy
50 - 75mm	133-143	±3µm
75 - 100mm	133-144	±4µm
100 - 125mm	133-145	±5µm
125 - 150mm	133-146	±5µm
150 - 175mm	133-147	±5µm
175 - 200mm	133-148	±5µm
200 - 225mm	133-149	±5µm
225 - 250mm	133-150	±6µm
250 - 275mm	133-151	±6µm
275 - 300mm	133-152	±6µm
300 - 325mm	133-153	±7µm
325 - 350mm	133-154	±7µm
350 - 375mm	133-155	±7µm
375 - 400mm	133-156	±8µm
400 - 425mm	133-157	±8µm
425 - 450mm	133-158	±8µm
450 - 475mm	133-159	±9µm
475 - 500mm	133-160	±9µm
500 - 525mm	133-161	±9µm
525 - 550mm	133-162	±10µm
550 - 575mm	133-163	±10µm
575 - 600mm	133-164	±10µm
600 - 625mm	133-165	±11µm
625 - 650mm	133-166	±11µm
650 - 675mm	133-167	±11µm
675 - 700mm	133-168	±12µm

Metric Individual		
Range	Order No.	Accuracy
700 - 725mm	133-169	±12µm
725 - 750mm	133-170	±12µm
750 - 775mm	133-171	±13µm
775 - 800mm	133-172	±13µm
800 - 825mm	133-173	±13µm
825 - 850mm	133-174	±14µm
850 - 875mm	133-175	±14µm
875 - 900mm	133-176	±14µm
900 - 925mm	133-177	±15µm
925 - 950mm	133-178	±15µm
950 - 975mm	133-179	±15µm
975 - 1000mm	133-180	±16µm

Inch Individual		
Range	Order No.	Accuracy
2" - 3"	133-223	±.00015"
3" - 4"	133-224	±.0002"
4" - 5"	133-225	±.00025"
5" - 6"	133-226	±.00025"
6" - 7"	133-227	±.00025"
7" - 8"	133-228	±.00025"
8" - 9"	133-229	±.00025"
9" - 10"	133-230	±.0003"
10" - 11"	133-231	±.0003"
11" - 12"	133-232	±.0003"

Tubular Inside Micrometers

SERIES 133



133-902

Metric Micrometer set		
Range	Order No.	Included in set
50 - 150mm (4 pcs. set)	133-901	<ul style="list-style-type: none"> • 133-143, 133-144, 133-145, 133-146 • with fitted case
50 - 300mm (10 pcs. set)	133-902	<ul style="list-style-type: none"> • 133-143, 133-144, 133-145, 133-146, 133-147, 133-148, 133-149, 133-150, 133-151, 133-152 • with fitted case

Inch Micrometer set		
Range	Order No.	Included in set
2" - 6" (4 pcs. set)	133-903	<ul style="list-style-type: none"> • 133-223, 133-224, 133-225, 133-226 • with fitted case
2" - 12" (10 pcs. set)	133-904	<ul style="list-style-type: none"> • 133-223, 133-224, 133-225, 133-226, 133-227, 133-228, 133-229, 133-230, 133-231, 133-232 • with fitted case

DIMENSIONS

Unit: mm

Order No.	L	a	b
133-145 / 133-225	100	5	3
133-146 / 133-226	125	5	3
133-147 / 133-227	150	18	15
133-148 / 133-228	175	18	15
133-149 / 133-229	200	18	15
133-180 / 133-232	975	18	15

Inside Micrometers

SERIES 141 — Interchangeable-Rod Type

FEATURES

- Wide range of ID measurements with interchangeable rods.
- Each interchangeable rod is marked with its measuring range.
- The sizes of interchangeable rods can be adjusted with spacing collars.
- Both micrometer head and furnished rods are satin-chrome finished throughout.
- Supplied in fitted plastic case. Over 1000mm / 40" supplied in wooden case.

Technical Data

Metric Model

Accuracy: $\pm(6+L/50)\mu\text{m}$
L=Maximum measuring length (mm)
Fraction rounded up

Inch Model

Accuracy: $\pm\{.00024+ (.00004 \times R/2)\}''$
R=Maximum measuring length (inch)
Fraction rounded up

Graduation: 0.01mm or .001"

Optional Accessories

---- : Setting ring (See page C-29.)



141-233



When using the extension rod

DIMENSIONS

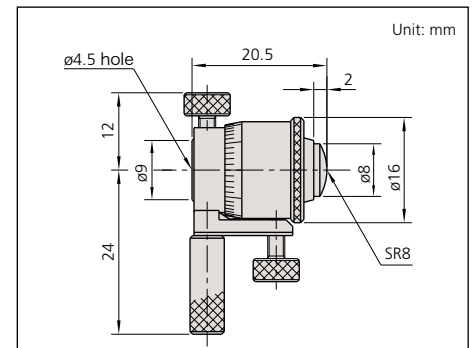

SPECIFICATIONS

Metric

Range	Order No.	Travel of micrometer head	Remarks
25 - 32mm	141-001 / 141-003*	7mm	Micrometer Head only
25 - 50mm	141-101 / 141-103*	7mm	with 2 rods
50 - 63mm	141-025 / 141-027*	13mm	Micrometer Head only
50 - 200mm	141-205 / 141-211*	13mm	with 3 rods
50 - 300mm	141-206 / 141-212*	13mm	with 5 rods
200 - 225mm	141-009 / 141-011*	25mm	Micrometer Head only
200 - 500mm	141-117	25mm	with 3 rods
200 - 1000mm	141-118	25mm	with 8 rods

*with carbide-tipped face

Inch

Range	Order No.	Travel of micrometer head	Remarks
1" - 1.25"	141-002 / 141-004*	.25"	Micrometer Head only
1" - 2"	141-102 / 141-104*	.25"	with 2 rods
2" - 2.5"	141-026 / 141-028*	.5"	Micrometer Head only
2" - 8"	141-208 / 141-214*	.5"	with 3 rods
2" - 12"	141-233 / 141-215*	.5"	with 5 rods
8" - 9"	141-010 / 141-012*	1"	Micrometer Head only
8" - 20"	141-121	1"	with 3 rods
8" - 40"	141-122	1"	with 8 rods

*with carbide-tipped face

Digimatic Tubular Inside Micrometers

SERIES 337 — Extension-Rod Type / SERIES 339 — Extension-Pipe Type



FEATURES

- Wide range of ID measurements by combining extension rods (pipes) and anvils with the micrometer head.
- The 339 Series uses highly durable extension pipes.
- Carbide-tipped measuring faces.
- Supplied in wooden case.



337-303



339-304



Metric — Extension-rod type

Range	Order No.	Travel of micrometer head	Extension rods
200 - 225mm	337-101	25mm	Micrometer Head only
200 - 1000mm	337-301	25mm	25mm, 50mm, 100mm (2 pcs.), 200mm, 300mm
200 - 1500mm	337-302	25mm	25mm, 50mm, 100mm, 200mm, 300mm (3 pcs.)

Inch/Metric — Extension-rod type

Range	Order No.	Travel of micrometer head	Extension rods
8 - 9" / 203.2 - 228.6mm	337-102	1"	Micrometer Head only
8 - 40" / 203.2 - 1016mm	337-303	1"	1", 2", 4" (2 pcs.), 8", 12"
8 - 60" / 203.2 - 1524mm	337-304	1"	1", 2", 4", 8", 12" (3 pcs.)

Metric — Extension-pipe type

Range	Order No.	Travel of micrometer head	Extension pipes
200 - 225mm	339-101	25mm	Micrometer Head only
200 - 1000mm	339-301	25mm	25mm, 50mm, 100mm, 200mm, 400mm
200 - 2000mm	339-302	25mm	25mm, 50mm, 100mm, 200mm (2 pcs.), 400mm (3 pcs.)

Inch/Metric — Extension-pipe type

Range	Order No.	Travel of micrometer head	Extension pipes
8 - 9" / 203.2 - 228.6mm	339-102	1"	Micrometer Head only
8 - 40" / 203.2 - 1016mm	339-303	1"	1", 2", 4", 8", 16"
8 - 80" / 203.2 - 1524mm	339-304	1"	1", 2", 4", 8" (2 pcs.), 16" (3 pcs.)

DIMENSIONS

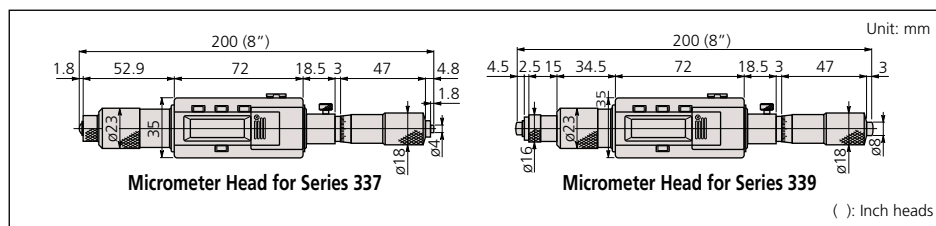

Technical Data

Metric Model

Accuracy: $\pm(3+n+L/50)\mu\text{m}$
 L=Maximum measuring length (mm)
 Fraction rounded up
 n=Number of rods
 Excluding quantizing error

Inch Model

Accuracy: $\pm\{.00015+.00005n+.00005R/2\}''$
 R=Maximum measuring length (inch)
 n=Number of rods
 Fraction rounded up

Resolution: 0.001mm or .0001"/0.001mm

Display: LCD

Battery: SR44 (1 pcs.), **938882**

Battery life: Approx. 8 months under normal use

Function

Zero/ABS, Data hold, Data output, Preset, inch/mm conversion (inch/mm models)

Alarm: Low voltage, Counting value composition error

Optional Accessories

05CZA662: SPC cable (1m)

05CZA663: SPC cable (2m)

----- : Setting ring (See page C-29.)



Tubular Inside Micrometers

SERIES 139 — Extension-Pipe Type

FEATURES

- Wide range of ID measurements by combining extension pipes and anvils with the micrometer head.
- Supplied in fitted wooden case, except 500 mm / 20" which comes in plastic case.



Metric Extension-pipe type

Range	Order No.	Travel of micrometer head	Extension pipes
100 - 125mm	139-001	25mm	Micrometer Head only
100 - 500mm	139-173	25mm	25mm, 50mm, 100mm, 200mm
100 - 900mm	139-174	25mm	25mm, 50mm, 100mm, 200mm, 400mm
100 - 1300mm	139-175	25mm	25mm, 50mm, 100mm, 200mm, 400mm (2 pcs.)
100 - 1700mm	139-176	25mm	25mm, 50mm, 100mm, 200mm, 400mm (3 pcs.)
100 - 2100mm	139-177	25mm	25mm, 50mm, 100mm, 200mm, 400mm (4 pcs.)

Inch Extension-pipe type

Range	Order No.	Travel of micrometer head	Extension pipes
4" - 5"	139-002	1"	Micrometer Head only
4" - 20"	139-178	1"	1", 2", 4", 8"
4" - 36"	139-179	1"	1", 2", 4", 8", 16"
4" - 52"	139-180	1"	1", 2", 4", 8", 16" (2 pcs.)
4" - 68"	139-181	1"	1", 2", 4", 8", 16" (3 pcs.)
4" - 84"	139-182	1"	1", 2", 4", 8", 16" (4 pcs.)



Inch Extension-pipe type

Range	Order No.	Travel of micrometer head	Extension pipes	Remarks
1.5 - 2"	139-004	.5"	Micrometer Head only	—
4 - 5"	139-006	1"	Micrometer Head only	—
1.5 - 12"	139-201	.5"	.5", 1", 2", 2.5", 3", 3.5", 4", 6"	Includes 139-004
4 - 40"	139-202	1"	1", 2", 3", 6", 9", 12", 14", 16", 17", 19"	Includes 139-006

DIMENSIONS

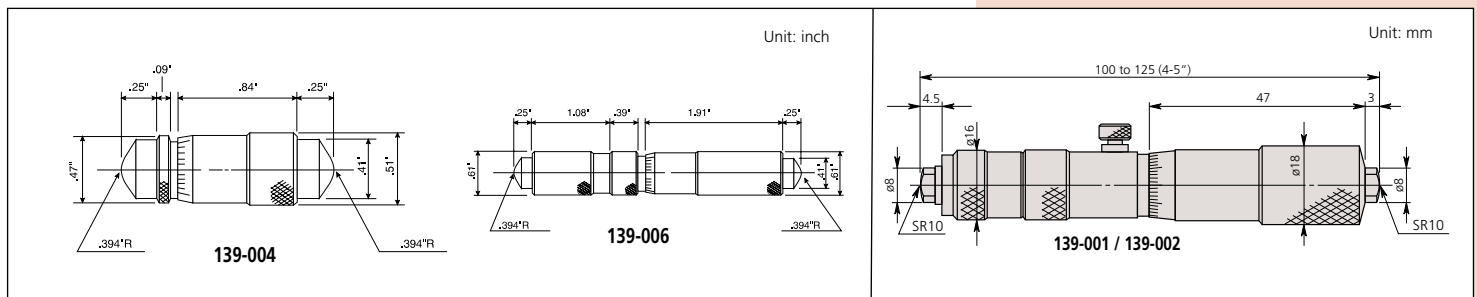

Technical Data

Metric Model

Accuracy:

- Series 139: $\pm(3+n+L/50)\mu\text{m}$
L=Maximum measuring length (mm)
n=number of rods
Fraction rounded up

Inch Model

Accuracy:

- Series 139: $\pm(.00015+.00005n+.00005R*/2)"$
R=Maximum measuring length (inch)
n=number of rods
Fraction rounded up

Graduation: 0.01mm or .001"

Measurement error of micrometer head: $\pm 3\mu\text{m}$

Optional Accessories

-----: Setting ring (See page C-29.)

Tubular Inside Micrometers

SERIES 140 — Extension-Pipe Type

Technical Data

Metric Model

Accuracy: $\pm(3+n+L/50)\mu\text{m}$
 n=Number of rod,
 L=Maximum measuring length (mm),
 Fraction rounded up

Inch Model

Accuracy: $\pm(.00015+.00005n+.00005R*/2)''$
 n=Number of rod
 R=Maximum measuring length (inch)
 Fraction rounded up

Graduation: 0.01mm or .001"

Optional Accessories

----- : Setting ring (See page C-29.)

FEATURES

- Wide range of ID measurements by combining extension rods (pipes) and anvils with the micrometer head.
- The Series 140 use highly durable/ large-diameter extension pipes.
- Supplied in fitted wooden case.

Metric — Extension-pipe type

Range	Order No.	Travel of micrometer head	Extension pipes
1000 - 2000mm	140-157	50mm	50mm, 100mm (2 pcs.), 200mm, 500mm
1000 - 3000mm	140-158	50mm	50mm, 100mm (2 pcs.), 200mm, 500mm, 1000mm
1000 - 4000mm	140-159	50mm	50mm, 100mm (2 pcs.), 200mm, 500mm, 1000mm (2 pcs.)
1000 - 5000mm	140-160	50mm	50mm, 100mm (2 pcs.), 200mm, 500mm, 1000mm (3 pcs.)

Inch — Extension-pipe type

Range	Order No.	Travel of micrometer head	Extension pipes
40" - 80"	140-161	2"	2", 4" (2 pcs.), 8", 20"
40" - 120"	140-162	2"	2", 4" (2 pcs.), 8", 20", 40"
40" - 160"	140-163	2"	2", 4" (2 pcs.), 8", 20", 40" (2 pcs.)
40" - 200"	140-164	2"	2", 4" (2 pcs.), 8", 20", 40" (3 pcs.)

DIMENSIONS

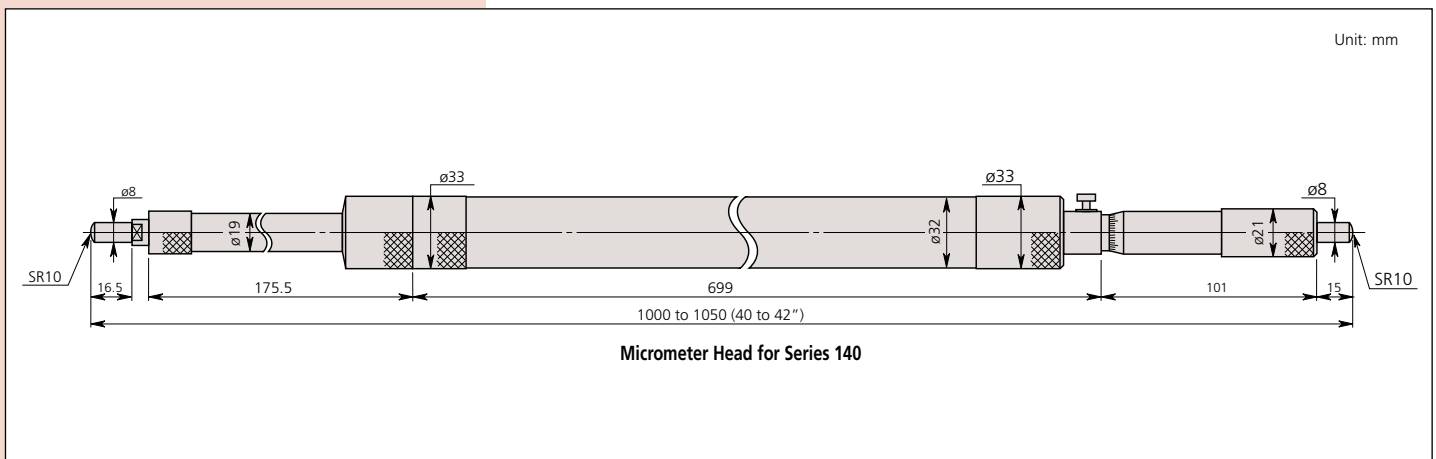

Inside Micrometers

SERIES 345, 145 — Caliper Type

FEATURES

- Caliper-type jaws are made of high-grade, tool steel.
- Locking clamp for positive locking of spindle.
- Non-slip grip finish (digital models)
- Satin-chrome finished.
- A special holder is available to be used with Mitutoyo micrometer stand.
- Supplied in fitted plastic case. Over 175mm / 4" supplied in wooden case.



SPECIFICATIONS

Metric		
Range	Order No.	Accuracy
5 - 30mm	345-250-30	±5µm
25 - 50mm	345-251-30	±6µm

Metric		
Range	Order No.	Accuracy
5 - 30mm	145-185	±5µm
25 - 50mm	145-186	±6µm
50 - 75mm	145-187	±7µm
75 - 100mm	145-188	±8µm
100 - 125mm	145-189	±9µm
125 - 150mm	145-190	±9µm
150 - 175mm	145-191	±10µm
175 - 200mm	145-192	±10µm
200 - 225mm	145-217	±11µm
225 - 250mm	145-218	±11µm
250 - 275mm	145-219	±12µm
275 - 300mm	145-220	±12µm

Inch/Metric Digital model		
Range	Order No.	Accuracy
.2 - 1.2" / 5-30mm	345-350-30	±.00025"
1 - 2" / 25-50mm	345-351-30	±.0003"

Inch		
Range	Order No.	Accuracy
.2 - 1.2"	145-193	±.00025"
1 - 2"	145-194	±.0003"
2 - 3"	145-195	±.00035"
3 - 4"	145-196	±.0004"

DIMENSIONS

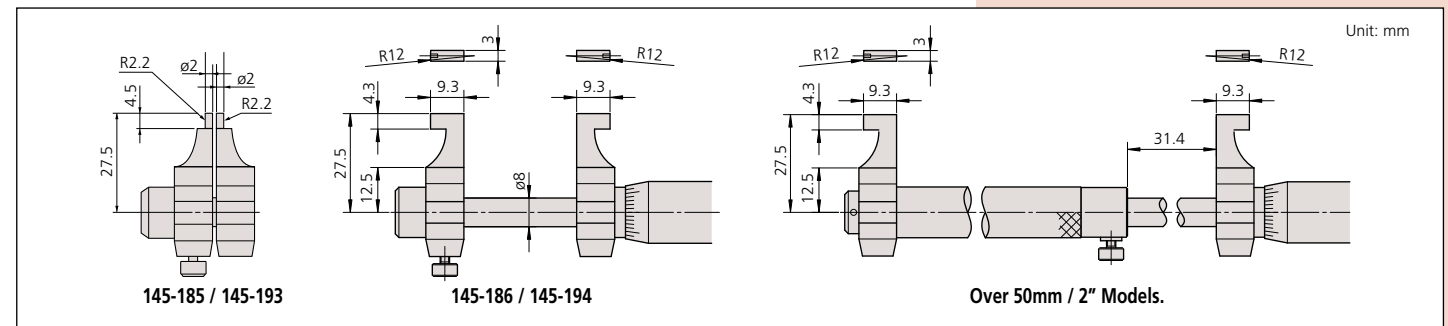

Technical Data

Accuracy: Refer to the list of specifications.
(excluding quantizing error for digital models)
Resolution*: 0.01mm or .00005"/0.001mm
Graduation**: 0.01mm or .001"
Measuring faces: Carbide tipped
Display*: LCD
Battery*: SR44 (1 pc.), **938882**
Battery life*: Approx. 2.4 years under normal use
*Digital models **Analog models

Function of Digital Model

Origin-set, Zero-setting, Data hold, Data output, inch/mm conversion (inch/mm models)
Function Lock, 2 Presets
Alarm: Low voltage, Counting value composition error

Optional Accessories

- 05CZA662**: SPC cable with data switch 1m / 40"
- 05CZA663**: SPC cable with data switch 2m / 80"
- : Setting ring (See page C-29.)
- 300401**: Cap for stand holder
- 300400**: Stand holder

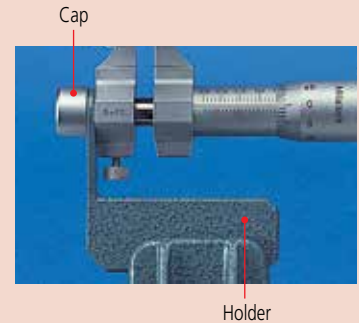



Inside Micro Checker

SERIES 515

FEATURES

- The Inside Micro Checker is designed to efficiently check the zero point of a tubular inside micrometer.
- Each measuring block is made of zirconia-based ceramic and is free from deterioration and dimensional changes over time.

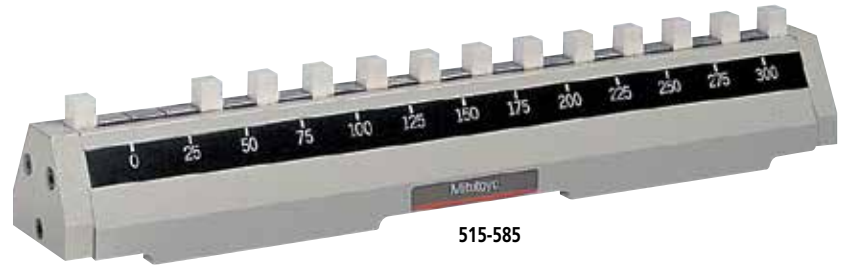

515-585



Standard accessory

Technical Data

Block pitch accuracy: $\pm(1+L/150)\mu\text{m}$
 L= Length to check (mm)

Standard Accessories

- 611671-02:** Auxiliary Block (10mm)
- 940286:** Clamping element with V-rest
- 602195:** Spacer (for $\varnothing 8\text{mm}$ measuring anvil)

Optional Accessories

- 602160:** Wooden case for 300mm Inside Micro Checker
- 602163:** Wooden case for 600mm Inside Micro Checker



SPECIFICATIONS

Range	Order No.	Length to check
300mm	515-585	25, 50, 75, 100, 125, 150, 175, 200, 225, 250, 275, 300mm
600mm	515-586	25, 50, 75, 100, 125, 150, 175, 200, 225, 250, 275, 300, 325, 350, 375, 400, 425, 450, 475, 500, 525, 550, 575, 600mm

DIMENSIONS

